



SEBASTIAN HANGER

TECHNICAL SPECIFICATIONS

Norde

Designed by
Norde Design Studio

FRAME STRUCTURE

ELECTROSTATIC PAINT ON METAL
WALNUT VENEERING WOODEN BASE

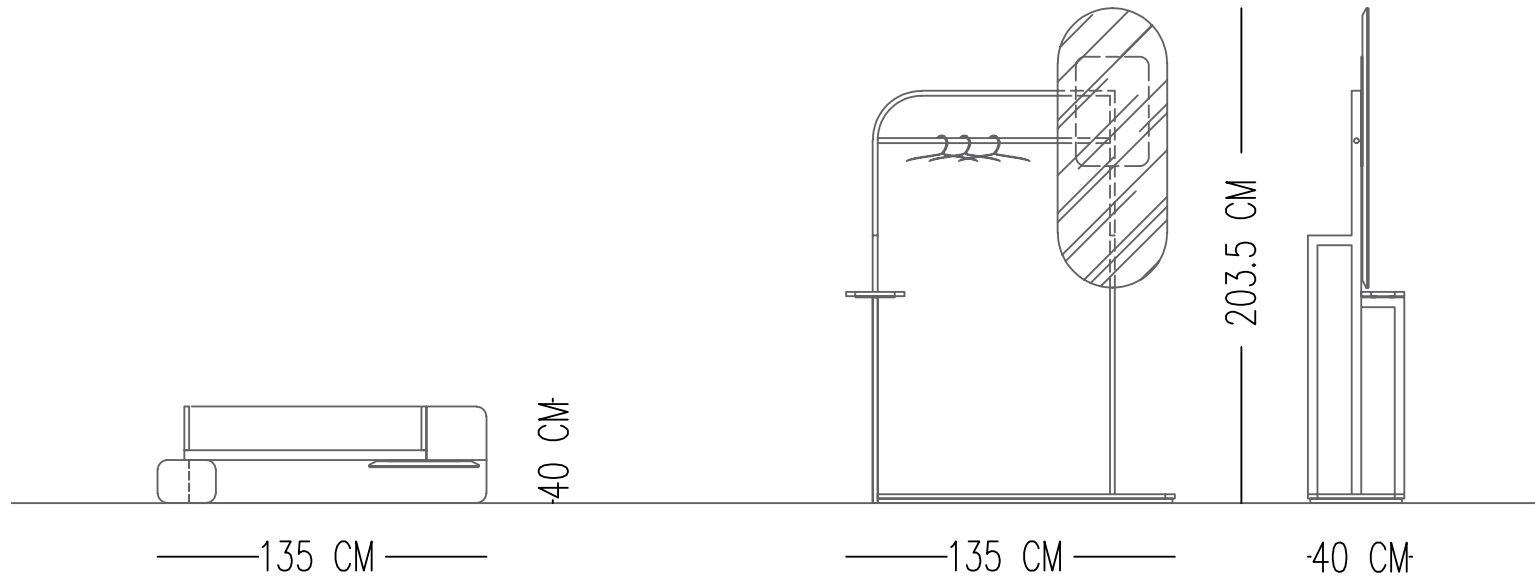
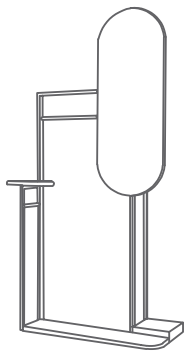

Catalog product

Frame Structure
Black painted metal

Clear Mirror

Walnut wood

Alternative material
All metal finishes in Norde Material Catalog
All oak wood veneering Norde Material Catalog
All mirror in Norde Material Catalog